

			Street Crane Co. Ltd				TITLE		CONTRACT No.		
C	MODEL CODE UPDATED TO MATCH NEW PRICE LIST. REF ECO-00522	MAP	09/12/2013			LX011 CHAIN HOIST CE DATA SHEET ELECTRIC TRAVEL (TYPE 'CE')		PART No. DLX-1005			
B	DIMENSION LAYOUT CHANGED. REF ECO-00429	ANIL	04/02/2011	DATE	DRAWN			CHECKED	SCALE	DRAWING No. 3 DLX-1005 C	
REV	DESCRIPTION	BY	DATE	29/08/2010	SW			CR	NTS	SHT 1 OF 3	

INFRINGEMENT OF COPYRIGHT. THIS DRAWING IS THE PROPERTY OF STREET CRANE COMPANY LTD AND MUST NOT BE COPIED OR SHOWN TO THIRD PARTIES WITHOUT THE WRITTEN PERMISSION OF STREET CRANE CO LTD, CHAPEL-EN-LE-FRITH, HIGH PEAK, SK23 0PH. U.K . T : +44 (0)1298 812456 F : +44 (0)1298 814945

ALL DIMENSIONS IN MILLIMETRES

LX011 CHAIN HOIST
ELECTRIC TROLLEY (Type CE) - RANGE 1

Steer Crane Model ref	Capacity kg	Speed m/min.	Power Kw	Falls of Chain	Ø Chain mm	C1 mm	C2 mm	C3 mm	D mm	D1 mm	D2 mm	F1 min mm	F1 max mm	G1 mm	H mm	I1 mm	I2 mm	I3 mm	I4 mm	L mm	L1 mm	M mm	M1 mm	M2 mm	O mm	P mm	S mm	S1 mm	S2 mm	Ø T mm	V mm	V1 mm	Ø Wheel mm	Z mm	Weight kg
LX011-M5125-005-1	125	5	0.5	1	4	154	230	200	125	164	57	64	140	24	12	158	131	194	157	158	92	375	88	96	156	279	164	157	144	14	147	172	65	19	57
LX011-M5125-008-1	125	8	0.5	1	4	154	230	200	125	164	57	64	140	24	12	158	131	194	157	158	92	375	88	96	156	279	164	157	144	14	147	172	65	19	57
LX011-M5125-012-1	125	14	1.0	1	4	154	230	200	125	164	57	64	140	24	12	158	131	194	157	158	92	375	88	96	156	279	164	157	144	14	147	172	65	19	59
LX011-M5125-014-2	125	1-4	0.2-0.5	1	4	154	230	200	125	164	57	64	140	24	12	158	131	194	157	158	92	375	88	96	156	279	164	157	144	14	147	172	65	19	57
LX011-M5125-028-2	125	2-8	0.2-0.5	1	4	154	230	200	125	164	57	64	140	24	12	158	131	194	157	158	92	375	88	96	156	279	164	157	144	14	147	172	65	19	59
LX011-M5125-314-2	125	3.5-14	0.2-0.5	1	4	154	230	200	125	164	57	64	140	24	12	158	131	194	157	158	92	375	88	96	156	279	164	157	144	14	147	172	65	19	59
LX011-M5250-005-1	250	5	0.5	1	4	154	230	200	125	164	57	64	140	24	12	158	131	194	157	158	92	375	88	96	156	279	164	157	144	14	147	172	65	19	57
LX011-M5250-008-1	250	8	0.5	1	4	154	230	200	125	164	57	64	140	24	12	158	131	194	157	158	92	375	88	96	156	279	164	157	144	14	147	172	65	19	57
LX011-M5250-012-1	250	12	1.0	1	5	154	230	200	125	164	57	64	140	24	12	158	131	194	157	158	92	375	88	96	156	279	164	157	144	14	147	172	65	19	59
LX011-M5250-016-1	250	16	1.0	1	5	154	230	200	125	164	57	64	140	24	12	158	131	194	157	158	92	375	88	96	156	279	164	157	144	14	147	172	65	19	59
LX011-M5250-014-2	250	1-4	0.2-0.5	1	4	154	230	200	125	164	57	64	140	24	12	158	131	194	157	158	92	375	88	96	156	279	164	157	144	14	147	172	65	19	57
LX011-M5250-028-2	250	2-8	0.25-1.0	1	5	154	238	221	125	174	56	64	140	24	12	160	129	197	162	158	95	385	88	96	156	279	182	167	144	14	153	175	65	23	59
LX011-M5250-312-2	250	3-12	0.25-1.0	1	5	154	238	221	125	174	56	64	140	24	12	160	129	197	162	158	95	385	88	96	156	279	182	167	144	14	153	175	65	23	65
LX011-M5500-004-1	500	4	0.8	1	5	154	230	200	125	164	57	64	140	24	12	160	129	96	256	158	95	390	88	96	156	279	164	157	144	14	147	172	65	23	59
LX011-M5500-006-1	500	6	0.8	1	5	154	230	200	125	164	57	64	140	24	12	160	129	96	256	158	95	390	88	96	156	279	164	157	144	14	147	172	65	23	59
LX011-M5500-008-1	500	8	1.0	1	5	154	238	221	125	174	56	64	140	24	12	160	129	197	162	158	95	400	88	96	156	279	182	167	144	14	153	175	65	23	65
LX011-M5500-012-1	500	12	1.5	1	5	154	238	221	125	174	56	64	140	24	12	160	129	197	162	158	95	400	88	96	156	279	182	167	144	14	153	175	65	23	65
LX011-M5500-015-2	500	1.2-5	0.25-1.0	1	5	154	238	221	125	174	56	64	140	24	12	160	129	197	162	158	95	400	88	96	156	279	182	167	144	14	153	175	65	23	65
LX011-M5500-028-2	500	2-8	0.4-1.8	1	7	123	260	232	140	174	53	73	160	30	12	163	121	213	164	162	102	405	90	99	165	280	219	181	143	18	158	177	70	29	74
LX011-M51000-004-1	1000	4	1.0	1	7	123	241	232	140	164	53	73	160	30	12	163	121	103	270	162	102	430	90	99	165	280	203	171	143	18	153	172	70	29	71
LX011-M51000-007-1	1000	7	1.6	1	7	123	260	232	140	174	53	73	160	30	12	163	121	213	164	162	102	440	90	99	165	280	219	181	143	18	158	177	70	29	74
LX011-M51000-014-2	1000	1-4	0.4-1.8	1	7	123	260	232	140	174	53	73	160	30	12	163	121	213	164	162	102	440	90	99	165	280	219	181	143	18	158	177	70	29	74
LX011-M51000-008-1	1000	9	2.0	1	10	210	275	231	170	182	64	73	160	30	12	171	120	222	171	162	110	505	90	99	157	282	270	220	154	24	170	190	70	35	98
LX011-M51000-028-2	1000	2-8	0.5-2.0	1	10	210	321	231	170	182	64	73	160	30	12	171	120	222	171	162	110	505	90	99	157	282	270	220	154	24	170	190	70	35	102

- FURTHER INFORMATION:**
- SUPPLY 400V 3PH 50 Hz
 - HOIST IP RATING IP54
 - CONTROL PANEL IP RATING IP65 CEI-EN
 - CONTROL VOLTAGE 48V
 - OPERATING TEMPERATURE: -20°C TO +50°C
 - MOTORS CLASS F INSULATION
 - OVERLOAD CLUTCH SET AT 115% OF SWL.
 - DUTY:

SPEED	%CDF	'M' RATING	FEM CLASS
SINGLE	40	M5	2m
DUAL	30/10	M5	2m

- HEIGHT OF LIFT (HOL) - 3m (STD) TO 10m MAX. CAN BE ORDERED WITH 1m INCREMENT.
- ADDITIONAL HOL MAY REQUIRE LARGER CHAIN BUCKET. DIMENSIONS 'C1', 'I3', 'S' AND WEIGHT MAY VARY THAN STANDARD SIZE.
- TROLLEY MOTOR SPEED- 7/14 m/min, POWER- 0.1/0.2 kW

LX MODEL CODE BREAKDOWN

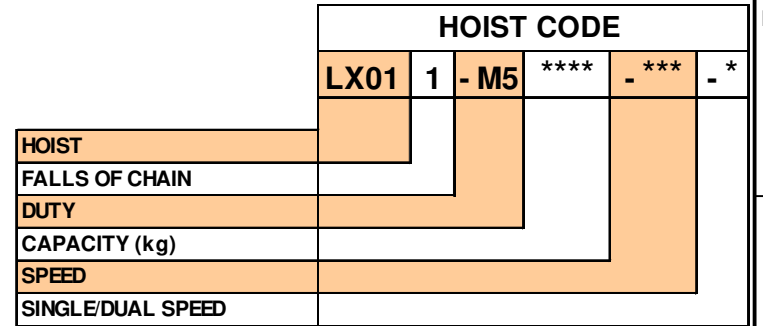

				Street Crane Co. Ltd				TITLE				CONTRACT No.				
C	MODEL CODE UPDATED TO MATCH NEW PRICE LIST. REF ECO-00522			MAP	09/12/2013			LX011 CHAIN HOIST CE DATA SHEET ELECTRIC TRAVEL (TYPE 'CE')				PART No. DLX-1005				
B	DIMENSION LAYOUT CHANGED. REF ECO-00429			ANIL	04/02/2011							DRAWING No. 3 DLX-1005 C				SHT 2 OF 3
REV	DESCRIPTION			BY	DATE			29/08/2010	SW	CR	NTS					

ALL DIMENSIONS IN MILLIMETRES

LX011 CHAIN HOIST
ELECTRIC TROLLEY (Type CE) - RANGE 2

Steet Crane Model ref	Capacity kg	Speed m/min.	Power Kw	Falls of Chain	Ø Chain mm	C1 mm	C2 mm	C3 mm	D mm	D1 mm	D2 mm	F1 min mm	F1 max mm	G1 mm	H mm	I1 mm	I2 mm	I3 mm	I4 mm	L mm	L1 mm	M mm	M1 mm	M2 mm	O mm	P mm	S mm	S1 mm	S2 mm	Ø T mm	V mm	V1 mm	Ø Wheel mm	Z mm	Weight kg
LX011-M5125-005-1	125	5	0.5	1	4	154	230	200	125	164	57	64	200	24	12	158	131	194	157	158	92	375	88	96	156	279	164	157	144	14	147	172	65	19	57
LX011-M5125-008-1	125	8	0.5	1	4	154	230	200	125	164	57	64	200	24	12	158	131	194	157	158	92	375	88	96	156	279	164	157	144	14	147	172	65	19	57
LX011-M5125-012-1	125	14	1.0	1	4	154	230	200	125	164	57	64	200	24	12	158	131	194	157	158	92	375	88	96	156	279	164	157	144	14	147	172	65	19	59
LX011-M5125-014-2	125	1-4	0.2-0.5	1	4	154	230	200	125	164	57	64	200	24	12	158	131	194	157	158	92	375	88	96	156	279	164	157	144	14	147	172	65	19	57
LX011-M5125-028-2	125	2-8	0.2-0.5	1	4	154	230	200	125	164	57	64	200	24	12	158	131	194	157	158	92	375	88	96	156	279	164	157	144	14	147	172	65	19	59
LX011-M5125-314-2	125	3.5-14	0.2-0.5	1	4	154	230	200	125	164	57	64	200	24	12	158	131	194	157	158	92	375	88	96	156	279	164	157	144	14	147	172	65	19	59
LX011-M5250-005-1	250	5	0.5	1	4	154	230	200	125	164	57	64	200	24	12	158	131	194	157	158	92	375	88	96	156	279	164	157	144	14	147	172	65	19	57
LX011-M5250-008-1	250	8	0.5	1	4	154	230	200	125	164	57	64	200	24	12	158	131	194	157	158	92	375	88	96	156	279	164	157	144	14	147	172	65	19	57
LX011-M5250-012-1	250	12	1.0	1	5	154	230	200	125	164	57	64	200	24	12	158	131	194	157	158	92	375	88	96	156	279	164	157	144	14	147	172	65	19	59
LX011-M5250-016-1	250	16	1.0	1	5	154	230	200	125	164	57	64	200	24	12	158	131	194	157	158	92	375	88	96	156	279	164	157	144	14	147	172	65	19	59
LX011-M5250-014-2	250	1-4	0.2-0.5	1	4	154	230	200	125	164	57	64	200	24	12	158	131	194	157	158	92	375	88	96	156	279	164	157	144	14	147	172	65	19	57
LX011-M5250-028-2	250	2-8	0.25-1.0	1	5	154	238	221	125	174	56	64	200	24	12	160	129	197	162	158	95	385	88	96	156	279	182	167	144	14	153	175	65	23	59
LX011-M5250-312-2	250	3-12	0.25-1.0	1	5	154	238	221	125	174	56	64	200	24	12	160	129	197	162	158	95	385	88	96	156	279	182	167	144	14	153	175	65	23	65
LX011-M5500-004-1	500	4	0.8	1	5	154	230	200	125	164	57	64	200	24	12	160	129	96	256	158	95	390	88	96	156	279	164	157	144	14	147	172	65	23	59
LX011-M5500-006-1	500	6	0.8	1	5	154	230	200	125	164	57	64	200	24	12	160	129	96	256	158	95	390	88	96	156	279	164	157	144	14	147	172	65	23	59
LX011-M5500-008-1	500	8	1.0	1	5	154	238	221	125	174	56	64	200	24	12	160	129	197	162	158	95	400	88	96	156	279	182	167	144	14	153	175	65	23	65
LX011-M5500-012-1	500	12	1.5	1	5	154	238	221	125	174	56	64	200	24	12	160	129	197	162	158	95	400	88	96	156	279	182	167	144	14	153	175	65	23	65
LX011-M5500-015-2	500	1.2-5	0.25-1.0	1	5	154	238	221	125	174	56	64	200	24	12	160	129	197	162	158	95	400	88	96	156	279	182	167	144	14	153	175	65	23	65
LX011-M5500-028-2	500	2-8	0.4-1.8	1	7	123	260	232	140	174	53	73	200	30	12	163	121	213	164	162	102	405	90	99	165	280	219	181	143	18	158	177	70	29	74
LX011-M51000-004-1	1000	4	1.0	1	7	123	241	232	140	164	53	73	200	30	12	163	121	103	270	162	102	430	90	99	165	280	203	171	143	18	153	172	70	29	71
LX011-M51000-007-1	1000	7	1.6	1	7	123	260	232	140	174	53	73	200	30	12	163	121	213	164	162	102	440	90	99	165	280	219	181	143	18	158	177	70	29	74
LX011-M51000-014-2	1000	1-4	0.4-1.8	1	7	123	260	232	140	174	53	73	200	30	12	163	121	213	164	162	102	440	90	99	165	280	219	181	143	18	158	177	70	29	74
LX011-M51000-008-1	1000	9	2.0	1	10	210	275	231	170	182	64	73	200	30	12	171	120	222	171	162	110	505	90	99	157	282	270	220	154	24	170	190	70	35	98
LX011-M51000-028-2	1000	2-8	0.5-2.0	1	10	210	321	231	170	182	64	73	200	30	12	171	120	222	171	162	110	505	90	99	157	282	270	220	154	24	170	190	70	35	102

FURTHER INFORMATION:

- 1) SUPPLY 400V 3PH 50 Hz
- 2) HOIST IP RATING IP54
- 3) CONTROL PANEL IP RATING IP65 CEI-EN
- 4) CONTROL VOLTAGE 48V
- 5) OPERATING TEMPERATURE: -20°C TO +50°C
- 6) MOTORS CLASS F INSULATION
- 7) OVERLOAD CLUTCH SET AT 115% OF SWL.
- 8) DUTY:

SPEED	%CDF	'M' RATING	FEM CLASS
SINGLE	40	M5	2m
DUAL	30/10	M5	2m

- 9) HEIGHT OF LIFT (HOL) - 3m (STD) TO 10m MAX. CAN BE ORDERED WITH 1m INCREMENT.
- 10) ADDITIONAL HOL MAY REQUIRE LARGER CHAIN BUCKET. DIMENSIONS 'C1', 'I3', 'S' AND WEIGHT MAY VARY THAN STANDARD SIZE.
- 11) TROLLEY MOTOR SPEED- 7/14 m/min, POWER- 0.1/0.2 kW

LX MODEL CODE BREAKDOWN

		HOIST CODE				
		LX01	1	- M5	****	- *** - *
HOIST						
FALLS OF CHAIN						
DUTY						
CAPACITY (kg)						
SPEED						
SINGLE/DUAL SPEED						

				Street Crane Co. Ltd				TITLE				CONTRACT No.							
C	MODEL CODE UPDATED TO MATCH NEW PRICE LIST. REF ECO-00522			MAP	09/12/2013			LX011 CHAIN HOIST CE DATA SHEET ELECTRIC TRAVEL (TYPE 'CE')				PART No. DLX-1005							
B	DIMENSION LAYOUT CHANGED. REF ECO-00429			ANIL	04/02/2011							DATE	DRAWN	CHECKED	SCALE	DRAWING No. 3 DLX-1005 C SHT 3 OF 3			
REV	DESCRIPTION			BY	DATE							29/08/2010	SW	CR	NTS				